



SAFER, STRONGER AC POWER CAPACITORS

AC Power Capacitors

Ideal for Power Factor and
Harmonic Filter Systems



FRAKO Kondensatoren-
und Anlagenbau
LKT 10.0-600
K18-1197

kvar	V/CFHz	A	kvar	V/CFHz	A
10.0	600	9.6	6.4	500	7.2
6.4	480	7.7	5.3	400	5.8
1.6	240	3.8	4.0	200	2.9
1.2	208	3.3	3.3	180	2.2

$U_{Max\ cont.} = 660\ V$
Temp.-CL. -40 +60 °C
3 x 24,6 μF -0...+5%

UL No.810 CSA C22.2 No.190pr
E 337088 MC 256833 no
ambient max. 46 °C

dry, non PCB Overpressure disconnect
EN 60831 IEC 60831
Made in Germany 109

Discharge before handling
Décharger avant manipulation

FRAKO Kondensatoren-
und Anlagenbau GmbH
LKT 25.0-480-DD6
K18-1138

kvar	V/60Hz	A	kvar	V/50Hz	A
25.0	480	30.1	20.8	480	25.1
6.3	240	15.0	15.6	415	21.7
4.7	208	13.0	13.1	380	19.8

$U_{Max\ cont.} = 528\ V$
temp.-Kl. -40 +60 °C tc 75 °C
3x95.9 μF -0...+5% Ui 3.9 / 12 kV

UL No.810 CSA C22.2 No.190protected 10,000
E 337088 MC 256833 not above 600VA
ambient max. 46 °C

dry, non PCB Overpressure disconnect
EN 60831 IEC 60831/11.201
Made in Germany 01100128_CBE

Discharge before handling
Décharger avant manipulation





SAFER, STRONGER AC POWER CAPACITORS

Achieve reliability and long life expectancy for your capacitor and filter systems

With over 90 years of experience producing capacitors, plus decades of leadership in the European market for power factor systems, **FRAKO** knows what it takes to produce capacitors that are highly reliable in real world applications for power factor and harmonic filter systems. **FRAKO** developed the LKT-DD60 and -DP60 ranges of dry type capacitors with a combination of safety features and strong ratings to assure satisfactory operation and life expectancy in power factor and harmonic filter systems.

SAFETY

Exclusive Four-Fold Safety Features

FRAKO goes to extensive lengths to ensure safety in each of their capacitors by combining four techniques that improve safety while minimizing the possibility of catastrophic failures. While all polypropylene power capacitors utilize self-healing metallized film, only **FRAKO** incorporates three additional levels of safety. **FRAKO** safety features include: Self-healing film, segmented film, all-phase disconnection for over-pressure and their patented coil contact ring.

1. Self-healing metallized film

The self-healing process occurs naturally in situations where adverse conditions cause an internal short circuit between two adjacent films. Self-healing is due to the heavy short circuit current that flows between films, causing the immediate vaporization of the metallized coatings, thus ending the short circuit. This feature has the important property that if localized over-loading occurs and punctures the substrate film, the fault automatically isolates itself. A portion of the metallization is vaporized to isolate the damaged area of the film and essentially stop the short circuit. This quickly stops the flow of short circuit current and enables the capacitor to continue in use.



Self-healing event in typical metallized film

2. Segmented Film

If several punctures occur in a localized area, the amount of energy involved may be too great for the self-healing process alone. This can lead to complete failure of the capacitor and traditional capacitors may actually explode in these cases. **FRAKO's** segmented film protects against severe internal short circuits. The polypropylene film used in **FRAKO** capacitors contains a metallization pattern of separate individual segments. Each segment is connected to the power supply by thin contact bridges which are precisely dimensioned to act like fuse links when a segment is severely overloaded (several substrate punctures within one segment). Under these severe conditions, the contact bridges (links) are vaporized (open) and the damaged segment is completely isolated from the power source.

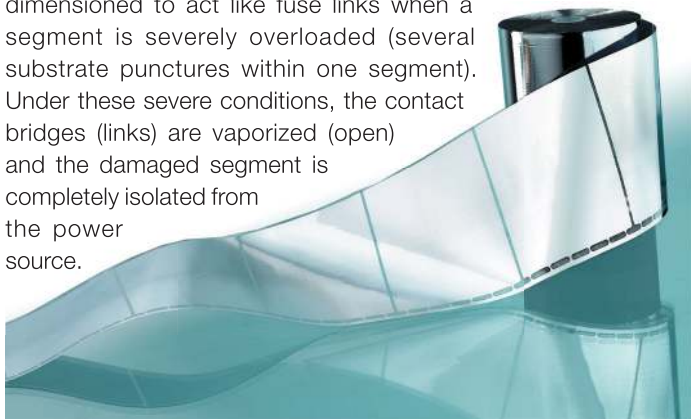

FRAKO Segmented, self-healing metallized film

3. All-phase Over-Pressure Disconnection

If an excessive internal pressure develops due to overloading or at the end of a capacitor's life, an over-pressure disconnection device activates to disconnect the capacitor. Over-pressure disconnection is required by international safety standards, to disconnect the capacitor from its power source when internal pressure, due to repeated self-healing or at the end of capacitor life, is too high. Most capacitors have the ability to disconnect power from only two of the three internal coils. While current flow does cease, there is still voltage applied to one of the windings. **FRAKO's** patented over-pressure disconnection method fully disconnects all three phases of the capacitor.

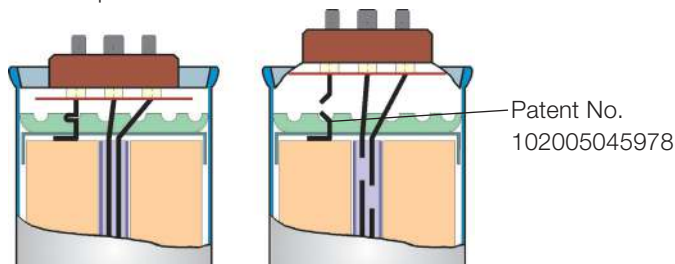

Overpressure disconnection system

Should puncturing of the dielectric occur on a major scale, the substrate may melt and this generates gases which increase internal case pressure. This causes the capacitor diaphragm (lid) to bulge upwards and increases the tension on the internal coil leads until they break at their defined locations. Bulging of the lid also increases internal volume, therefore reduces pressure inside the capacitor.

4. Solder-Free Contact Ring

FRAKO added this key patented safety and reliability feature in 2015. These contact rings enable **FRAKO** to connect the capacitor lead wires to each internal coil without soldering, without any heat at all. This process eliminates the traditional risk of damage to capacitor windings caused by soldering. The heat required for soldering, the standard method of attaching leads in the past, tends to burn away some of the polypropylene film and may cause slight weakening of the capacitor. **FRAKO's** new patented technology securely fastens each lead and makes secure connections to each coil, without any heat. Not only does this make a more reliable capacitor, it enables us to produce these as lead-free capacitors in full RoHS compliance.

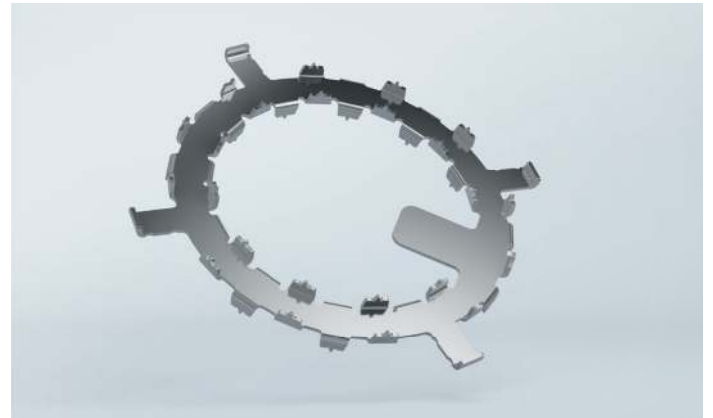

Contact ring (Patent no. US10,256,042 B2 / Date of Patent: Apr. 9, 2019)

The contact rings are stamped from a special alloy and are formed with a number of protrusions that are pressed into the zinc end-faces of each coil. Prior to pressing into the coil, the lead wires are spot welded onto the contact ring. The great advantage of this solder-free design, is that it has completely eliminated the risk of damaging a capacitor coil at the manufacturing stage due to overheating during the lead attachment process. The quality of the coil connection is significantly increased and the reliability of the over-pressure disconnection is improved since the leads are more securely held in place, even during such adverse conditions as coil overheating, where previously the solder may melt.

The patented contact ring enables **FRAKO** to produce completely lead-free capacitors in accordance with RoHS and offer another improvement to their operating reliability.

Four-Fold Safety Features:

- Self-healing metallized film
- Segmented film
- All-phase Over-Pressure Disconnection
- Solder-Free Contact Ring

It all adds up to reliability and safety with long life and RoHS compliance.



SAFER, STRONGER AC POWER CAPACITORS

Achieve reliability and long life expectancy for your capacitor and filter systems

Power systems today demand a stronger capacitor than in the past. Most electrical power systems have harmonic voltage and current distortion, which will cause higher capacitor currents and raise the internal temperatures within the capacitor system enclosure. **FRAKO** developed the type DD60 and DP60 capacitors with a combination of safety features and strong ratings to assure reliability and long life expectancy within power systems that have current and voltage distortion. These capacitors are uniquely designed for long life in power factor and harmonic filter systems.

CAPABILITY

High Ambient Temperature Capability

Inside of electrical enclosures for power factor capacitors or harmonic filters, temperatures may be 10°C to 20°C degrees hotter than the ambient room air. Many capacitors require derating whenever the air temperature around the capacitor exceeds 35°C to 46°C.

FRAKO capacitors are rated for continuous use in a surrounding air temperature of up to 60°C degrees (no derating necessary).

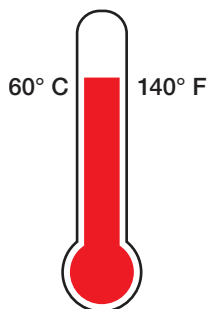

High Harmonic Current Capability

Whether a capacitor is used in a power factor system or in a harmonic filter, today's capacitor installations are typically subjected to harmonics.

System harmonics can increase the capacitor current above its rated capability and will also increase the capacitor internal temperature. This contributes to shortened capacitor life.

FRAKO capacitors are designed and rated for high harmonic current and can continuously carry up to 165% of their nominal capacitor current.

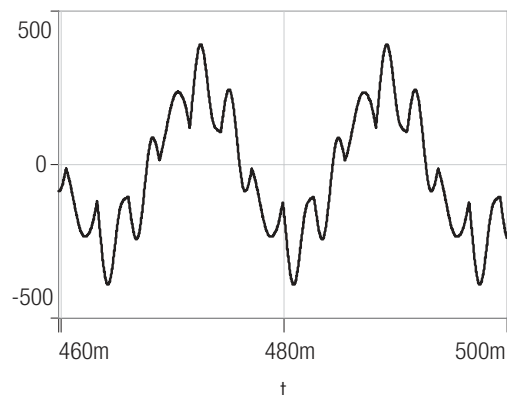

Secure, Maintenance Free Terminals

Terminals are a common failure point in capacitor systems because over time the typical screw terminals can loosen, resulting in a high resistance connection and ultimate failure of the wiring or terminal.

FRAKO-DD60 and **-DP60** capacitors are supplied with (factory installed) screwless terminations that secure wiring with a maintenance free, antivibration connection. Not only are they easy to wire, but they also maintain terminal pressure for the lifetime of the capacitor.

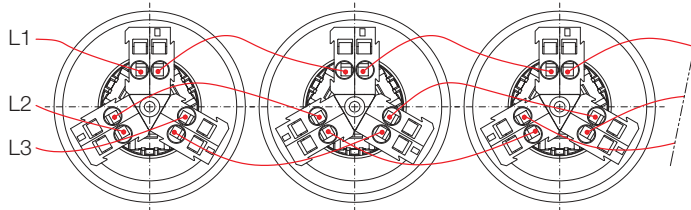

Series wiring of capacitors. The maximum current must not be exceeded. (This applies to capacitors with diameter 60/70 mm)



AKD type connection terminal for LKT type Power Capacitors of 85 mm diameter

Stripping length: 16 mm
Max. current (rated): 75 A



AKD type connection terminal for LKT type Power Capacitors of 60/70 mm diameter

Stripping length: 13 mm
Max. current (rated): 41 A

LKT 3-PHASE DRY-TYPE CAPACITORS

Construction Details

FRAKO produces AC Power Capacitors using their unique Dry-Type construction to provide high reliability in rigorous applications of power factor and harmonic filter systems. For best capacitor performance and longest life expectancy, **FRAKO** combines optimized winding construction for low internal heating with unique heat removal techniques. **FRAKO** dry-type capacitors may be mounted in horizontal or vertical orientation.

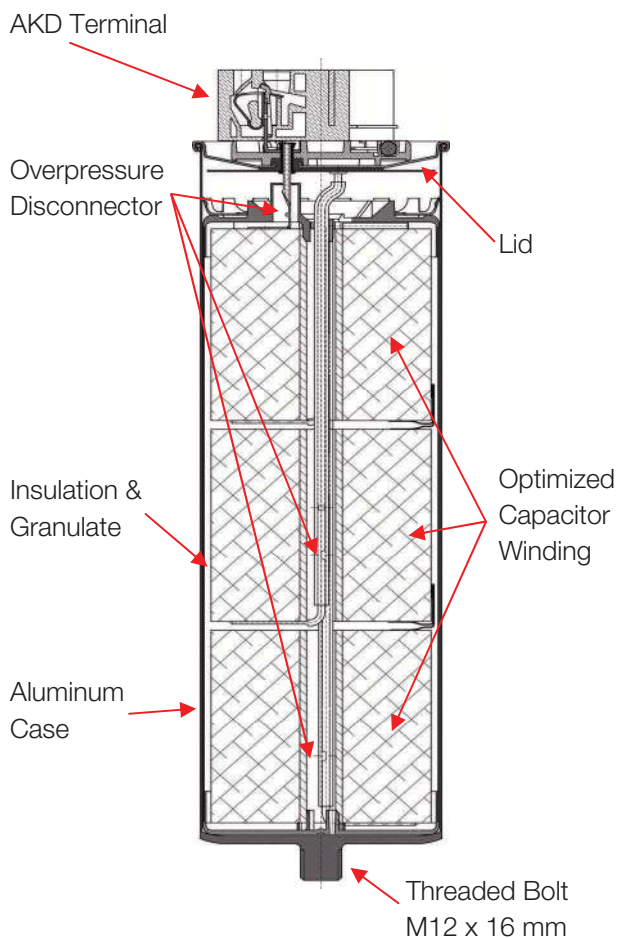

Optimized Winding Geometry

FRAKO produces capacitor windings using relatively short coils with moderate diameters because this coil geometry is known to generate much less internal heat than other winding construction methods.

Oil Treated Polypropylene Film

FRAKO applies a thin film of vegetable oil to the entire surface of each winding to facilitate heat transfer and to prevent oxidation of the metalized winding surface.

Absorbent Granulate



FRAKO capacitors are filled with dry absorbent granulate to assure the absence of liquid (oil), for heat dissipation and for improved safety by enabling overpressure disconnection to occur at lower internal pressure.

Standard Features that exceed Industry Standards

- No Leak, Dry-Type Construction
- Factory Installed Discharge Resistors
- Finger-Safe Maintenance Free Terminals
- Compact Design
- High Current Capability
- Handles Harmonic Current
- High Temperature Rating
- Four Safety Features
- Handles High Altitude

LKT 3-PHASE DRY-TYPE CAPACITORS

General Specification

Type		LKT ...-DD60	LKT ...-DP60
Safety Features		Self-healing polypropylene film, segmented metallized film 3-phase overpressure disconnect, Solder-free contact ring	
Applicable Standards		UL 810, CSA 22.2 No. 190, IEC/EN 60831-1 and -2	
Agency Approvals		  E337088 MC258833	
Rated Voltage	V_{Nom}	240, 480 & 600V	690 & 800V
Maximum Voltage (continuous)	V_{Max}	110 % of Rated Voltage	100 % of Rated Voltage
Rated Frequency	f_N	60 Hz, may also be used at 50 Hz	
Tolerance (μF and KVAR)		-0 % / +5 %	
Internal Connection		delta	
Maximum Current (continuous)		$165 \% \times I_{Nom}$	$150 \% \times I_{Nom}$
Power Losses		$\leq 0.2 \text{ W/kVAR}$ (dielectric) $\leq 0.5 \text{ W/kVAR}$ (total)	
Discharge (resistors factory installed)		$\leq 50 \text{ V}$, within 60 seconds discharge	
Max. temporary Overvoltage		$110 \% V_{MAX}$, 8 hours per day $115 \% V_{MAX}$, 30 minutes per day $120 \% V_{MAX}$, 5 minutes $130 \% V_{MAX}$, 1 minute	$110 \% V_{Nom}$, 8 hours per day $115 \% V_{Nom}$, 30 minutes per day $120 \% V_{Nom}$, 5 minutes $130 \% V_{Nom}$, 1 minute
Maximum Inrush Current	I_S	$228 \times I_{Nom}$	$208 \times I_{Nom}$
Routine Voltage Test (Terminal / Terminal)	V_{TT}	$2.15 \times V_{Max}$, 2 seconds, plus $1.85 \times V_{Max}$, 18 seconds	
Routine Voltage Test (Terminal / Case)	V_{TC}	$V_{Nom} < 600 \text{ V} = 3,900 \text{ V}$, 2 seconds $V_{Nom} \geq 600 \text{ V} = 4,300 \text{ V}$, 2 seconds	
Other Routine Tests		Case seal test, capacitance, loss factor and resistance measurement	
Ambient Temperature (continuous)		-40° C to 60° C	
Case Temperature (max.)		75° C	
Storage Temperature (min. /max.)		-40° C to 85° C	
Humidity (max.)		95 % non-condensating	
Altitude (max.)		4,000 meters above sea level	
Life Expectancy		160,000 hours (at max voltage, current, ambient) with up to 40,000 switchings per year	
Mounting and Fixing		Vertical or horizontal by M12 × 16 mm stud (15 Nm tightening torque)	
Terminals		Screwless pressure connection for all capacitors. Accepts stranded or fine stranded CU wires, or ferrules wire range (85 mm capacitors): 1 × 15 AWG to 6 AWG wire range (60/70 mm capacitors): 2 × 17 AWG to 10 AWG	

PRODUCT SELECTION & TECHNICAL DATA

Type DD60 Capacitors for 240 V / 60 Hz System Voltage

FRAKO type LKT -DD60 240 V capacitors are multipurpose capacitors for use in Power Factor and Harmonic Filter Systems.

Continuous voltage capability of 110 % rated voltage makes them suitable for use with or without a series (tuning, detuning or filter) reactor.

Permitted operating & overvoltages	
Max. Voltage (continuous)	264V
8 hours / day	290V
30 minutes / day	304V
5 minutes	317V
1 minute	343V

Product Selection Chart

Catalogue No.	Power	Power	Capacitance	Current		ESR at 1 kHz [mΩ]	Dimensions d × h [mm]	Weight [kg]	Part No.
	Q_C [kVAR]	w / 7 % [kVAR]		$C_N \Delta$ [μF]	I_{Nom} [A]				
Rated Voltage: 240 V / 60 Hz									
LKT 1.0-240-DD60	1.00	1.10	3 × 15.3	2.4	4.0	3 × 3.5	60 × 179	0.60	31-10970
LKT 1.5-240-DD60	1.50	1.60	3 × 23.0	3.6	5.9	3 × 2.3	60 × 179	0.60	31-10971
LKT 2.0-240-DD60	2.00	2.20	3 × 30.7	4.8	7.9	3 × 1.7	60 × 179	0.60	31-10972
LKT 2.5-240-DD60	2.50	2.70	3 × 38.3	6.0	9.9	3 × 1.4	60 × 179	0.60	31-10973
LKT 3.0-240-DD60	3.00	3.20	3 × 46.0	7.2	11.9	3 × 1.2	60 × 179	0.60	31-10974
LKT 4.0-240-DD60	4.00	4.30	3 × 61.4	9.6	15.8	3 × 0.9	60 × 179	0.60	31-10975
LKT 5.0-240-DD60	5.00	5.40	3 × 76.7	12.0	19.8	3 × 0.7	60 × 251	0.85	31-10976
LKT 6.0-240-DD60	6.00	6.50	3 × 92.1	14.4	23.8	3 × 0.6	60 × 251	0.85	31-10977
LKT 7.5-240-DD60	7.50	8.10	3 × 115.0	18.0	29.7	3 × 0.5	85 × 194	1.20	31-10909
LKT 8.33-240-DD60	8.33	8.90	3 × 127.8	20.0	33.0	3 × 0.4	85 × 194	1.20	31-10910
LKT 10.0-240-DD60	10.00	10.80	3 × 153.4	24.0	39.8	3 × 0.3	85 × 194	1.20	31-10911
LKT 11.7-240-DD60	11.70	12.60	3 × 179.0	28.0	46.4	3 × 0.3	85 × 194	1.20	31-10912
LKT 12.5-240-DD60	12.50	13.40	3 × 191.7	30.0	49.7	3 × 0.3	85 × 246	1.55	31-10913
LKT 15.0-240-DD60	15.00	16.10	3 × 230.1	36.0	59.6	3 × 0.2	85 × 246	1.55	31-10914
LKT 16.7-240-DD60	16.70	18.00	3 × 255.7	40.0	66.3	3 × 0.2	85 × 246	1.55	31-10915
LKT 17.5-240-DD60	17.50	18.80	3 × 266.4	42.0	69.1	3 × 0.2	85 × 246	1.55	31-10916
LKT 20.0-240-DD60	20.00	21.50	3 × 306.8	48.0	79.4	3 × 0.2	85 × 309	1.90	31-10917

PRODUCT SELECTION & TECHNICAL DATA

Type DD60 Capacitors for 480 V / 60Hz System Voltage

FRAKO type LKT -DD60 480V capacitors are multipurpose capacitors for use in Power Factor and Harmonic Filter Systems.

Continuous voltage capability of 110% rated voltage makes them suitable for use with or without a series (tuning, detuning or filter) reactor.

Permitted operating & overvoltages	
Max. Voltage (continuous)	528V
8 hours / day	581V
30 minutes / day	607V
5 minutes	634V
1 minute	686V

Product Selection Chart

Catalogue No.	Power Q_C [kVAR]	Power w / 7 % [kVAR]	Capacitance $C_N \Delta$ [μ F]	Current		ESR at 1 kHz [m Ω]	Dimensions d x h [mm]	Weight [kg]	Part No.
				I_{Nom} [A]	I_{Max} [A]				
Rated Voltage: 480 V / 60 Hz									
LKT 1.0-480-DD60	1.00	1.10	3 x 3.8	1.2	2.0	3 x 14.0	60 x 179	0.60	31-10978
LKT 1.5-480-DD60	1.50	1.60	3 x 5.8	1.8	3.0	3 x 9.2	60 x 179	0.60	31-10979
LKT 2.0-480-DD60	2.00	2.20	3 x 7.7	2.4	4.0	3 x 6.9	60 x 179	0.60	31-10980
LKT 2.5-480-DD60	2.50	2.70	3 x 9.6	3.0	5.0	3 x 5.5	60 x 179	0.60	31-10981
LKT 3.0-480-DD60	3.00	3.20	3 x 11.5	3.6	5.9	3 x 4.6	60 x 179	0.60	31-10982
LKT 4.0-480-DD60	4.00	4.30	3 x 15.4	4.8	7.9	3 x 3.4	60 x 179	0.60	31-10983
LKT 5.0-480-DD60	5.00	5.40	3 x 19.2	6.0	9.9	3 x 2.8	60 x 251	0.85	31-10984
LKT 6.0-480-DD60	6.00	6.50	3 x 23.1	7.2	11.9	3 x 2.3	60 x 251	0.85	31-10985
LKT 7.5-480-DD60	7.50	8.10	3 x 28.9	9.0	14.9	3 x 1.8	60 x 251	0.85	31-10986
LKT 9.4-480-DD60	9.40	8.90	3 x 35.9	11.3	18.6	3 x 1.5	70 x 251	1.10	31-10987
LKT 10.0-480-DD60	10.00	10.80	3 x 38.5	12.0	19.8	3 x 1.4	70 x 251	1.10	31-10988
LKT 11.7-480-DD60	11.70	12.60	3 x 44.9	14.0	23.3	3 x 1.2	70 x 251	1.10	31-10989
LKT 12.5-480-DD60	12.50	13.40	3 x 48.1	15.0	24.8	3 x 1.1	85 x 246	1.55	31-10930
LKT 15.0-480-DD60	15.00	16.10	3 x 57.4	18.0	29.7	3 x 0.9	85 x 246	1.55	31-10931
LKT 16.7-480-DD60	16.70	18.00	3 x 64.2	20.0	33.2	3 x 0.8	85 x 246	1.55	31-10932
LKT 17.5-480-DD60	17.50	18.80	3 x 67.0	21.0	34.7	3 x 0.8	85 x 309	1.90	31-10933
LKT 18.8-480-DD60	18.80	20.20	3 x 72.2	22.6	37.3	3 x 0.7	85 x 309	1.90	31-10934
LKT 20.0-480-DD60	20.00	21.50	3 x 76.7	24.0	39.8	3 x 0.7	85 x 309	1.90	31-10935
LKT 22.5-480-DD60	22.50	24.20	3 x 86.3	27.0	44.7	3 x 0.6	85 x 309	1.90	31-10936
LKT 23.4-480-DD60	23.40	25.20	3 x 89.8	28.1	46.4	3 x 0.6	85 x 309	1.90	31-10937
LKT 25.0-480-DD60	25.00	26.90	3 x 95.9	30.0	49.7	3 x 0.6	85 x 351	2,20	31-10938

PRODUCT SELECTION & TECHNICAL DATA

Type DD60 Capacitors for 600 V / 60 Hz System Voltage

FRAKO type LKT -DD60 600V capacitors are multipurpose capacitors for use in Power Factor and Harmonic Filter Systems.

Continuous voltage capability of 110 % rated voltage makes them suitable for use with or without a series (tuning, detuning or filter) reactor.

Permitted operating & overvoltages	
Max. Voltage (continuous)	660V
8 hours / day	726V
30 minutes / day	759V
5 minutes	792V
1 minute	858V

Product Selection Chart

Catalogue No.	Power	Power	Capacitance	Current		ESR at 1 kHz [mΩ]	Dimensions d × h [mm]	Weight [kg]	Part No.
	Q_C [kVAR]	w / 7 % [kVAR]		$C_N \Delta$ [μF]	I_{Nom} [A]				
Rated Voltage: 600 V / 60 Hz									
LKT 1.0-600-DD60	1.00	1.10	3×2.4	1.0	1.6	3×22.1	60×179	0.60	31-10990
LKT 1.5-600-DD60	1.50	1.60	3×3.7	1.5	2.4	3×14.3	60×179	0.60	31-10991
LKT 2.0-600-DD60	2.00	2.20	3×4.9	1.9	3.2	3×10.8	60×179	0.60	31-10992
LKT 2.5-600-DD60	2.50	2.70	3×6.1	2.4	4.0	3×8.7	60×179	0.60	31-10993
LKT 3.0-600-DD60	3.00	3.20	3×7.3	2.9	4.8	3×7.3	60×179	0.60	31-10994
LKT 4.0-600-DD60	4.00	4.30	3×9.7	3.8	6.4	3×5.5	60×179	0.60	31-10995
LKT 5.0-600-DD60	5.00	5.40	3×12.4	4.8	7.9	3×4.3	60×251	0.85	31-10996
LKT 6.0-600-DD60	6.00	6.50	3×14.8	5.8	9.5	3×3.6	60×251	0.85	31-10997
LKT 7.5-600-DD60	7.50	8.10	3×18.5	7.2	11.9	3×2.9	60×251	0.85	31-10998
LKT 10.0-600-DD60	10.00	10.80	3×24.6	9.6	15.9	3×2.2	70×251	1.10	31-10999
LKT 11.7-600-DD60	11.70	12.60	3×28.8	11.3	18.6	3×1.8	85×246	1.55	31-10949
LKT 12.5-600-DD60	12.50	13.40	3×30.7	12.0	19.8	3×1.7	85×246	1.55	31-10950
LKT 15.0-600-DD60	15.00	16.10	3×36.9	14.4	23.8	3×1.4	85×246	1.55	31-10951
LKT 16.7-600-DD60	16.70	18.00	3×41.0	16.1	26.6	3×1.3	85×309	1.90	31-10952
LKT 17.5-600-DD60	17.50	18.80	3×43.0	16.8	27.8	3×1.2	85×309	1.90	31-10953
LKT 20.0-600-DD60	20.00	21.50	3×49.1	19.2	31.7	3×1.1	85×309	1.90	31-10954
LKT 22.5-600-DD60	22.50	24.20	3×55.2	21.7	35.7	3×1.0	85×351	2,20	31-10955
LKT 23.4-600-DD60	23.40	25.20	3×57.4	22.5	37.2	3×0.9	85×351	2,20	31-10956
LKT 25.0-600-DD60	25.00	26.90	3×61.5	24.1	39.7	3×0.9	85×351	2,20	31-10957

PRODUCT SELECTION & TECHNICAL DATA

Type DD60 Capacitors for 690 and 800 V / 60Hz System Voltage

FRAKO type LKT -DD60 690 and 800V capacitors are multipurpose capacitors for use in Power Factor and Harmonic Filter Systems.

Continuous voltage capability of 110% rated voltage makes them suitable for use with or without a series (tuning, detuning or filter) reactor.

Permitted operating & overvoltages	
Max. Voltage (continuous)	690V / 800V
8 hours / day	759V / 880V
30 minutes / day	794V / 920V
5 minutes	828V / 960V
1 minute	897V / 1040V

Product Selection Chart

Catalogue No.	Power Q_C [kVAR]	Power w / 7 % [kVAR]	Capacitance $C_N \Delta$ [μ F]	Current		ESR at 1 kHz [m Ω]	Dimensions d x h [mm]	Weight [kg]	Part No.
				I_{Nom} [A]	I_{Max} [A]				
Rated Voltage: 690 V / 60 Hz									
LKT 12.5-690-DP60	12.50	13.40	3 x 23.2	10.5	15.7	3 x 2.3	70 x 251	1.10	31-11000
LKT 15.0-690-DP60	15.00	16.10	3 x 27.9	12.6	18.8	3 x 1.9	85 x 246	1.55	31-10959
LKT 16.5-690-DP60	16.50	17.10	3 x 30.6	13.8	20.7	3 x 1.8	85 x 246	1.55	31-10969
LKT 20.0-690-DP60	20.00	21.40	3 x 37.1	16.7	25.1	3 x 1.4	85 x 246	1.55	31-10960
LKT 22.1-690-DP60	22.10	23.70	3 x 41.0	18.5	27.7	3 x 1.3	85 x 309	1.90	31-10961
LKT 25.0-690-DP60	25.00	26.80	3 x 46.4	20.9	31.4	3 x 1.1	85 x 309	1.90	31-10962
LKT 30.0-690-DP60	30.00	32.10	3 x 55.7	25.1	37.7	3 x 1.0	85 x 351	2.20	31-10963
LKT 33.0-690-DP60	33.00	35.30	3 x 61.3	27.6	41.4	3 x 2.1	85 x 351	2.20	31-11003
Rated Voltage: 800 V / 60 Hz									
LKT 8.0-800-DP60	8.00	8.60	3 x 11.0	5.8	8.7	3 x 4.8	60 x 251	0.85	31-11001
LKT 12.6-800-DP60	12.60	13.50	3 x 17.4	9.1	13.7	3 x 3.0	70 x 251	1.10	31-11002
LKT 16.0-800-DP60	16.00	17.10	3 x 22.1	11.5	17.3	3 x 2.4	85 x 246	1.55	31-10966
LKT 25.2-800-DP60	25.20	27.00	3 x 34.8	18.6	27.3	3 x 1.5	85 x 309	1.90	31-10967

TECHNICAL DATA

Dimensional Data

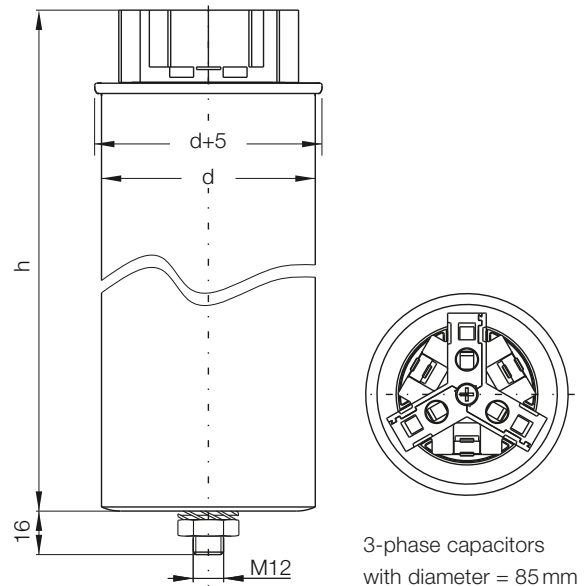
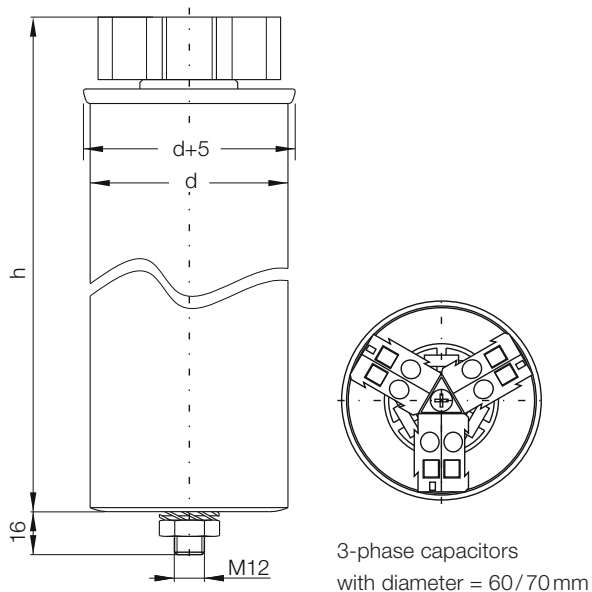

Applying capacitors to other voltages or frequencies

When applying capacitors at a lower voltage, the kVAR rating reduces. Use the factors in the table below to calculate the kVAR rating for your capacitor when used in lower system voltage.

System Voltage	Capacitor Voltage				
	240 V	480 V	600 V	690 V	800 V
208 V	0.75	0.19	0.12	0.09	0.07
240 V	1.00	0.25	0.16	0.12	0.09
380 V	–	0.63	0.40	0.30	0.23
480 V	–	1.00	0.64	0.48	0.36
600 V	–	–	1.00	0.76	0.56

When a 60Hz rated capacitor will be operated in a 50Hz network, the kVAR rating is reduced. Apply the factor of 0.83 to the capacitor 60Hz kVAR rating to determine the 50Hz kVAR rating.

Voltage example:

Operating a 25kVAR, 480V (60Hz) capacitor in a 380V (60Hz) system:
 $25 \text{ kVAR} \times 0.63 = 15.8 \text{ kVAR}$

Frequency example:

Operating a 25kVAR, 60Hz capacitor in a 50Hz system:
 $25 \text{ kVAR} \times 0.83 = 20.8 \text{ kVAR}$

CAPACITOR CALCULATIONS

Capacitance C	[F]	$C = \frac{kVAR \times 1000}{V_{LL}^2 \times 2\pi f}$
Capacitor Power Q_C	[kVAR]	$kVAR = Q_C = \frac{2\pi f \times C \times V_{LL}^2}{1000}$
Capacitor Power Q_C when operated with harmonic filter reactor	[kVAR]	$kVAR = Q_C = \left(\frac{2\pi f \times C \times V_{LL}^2}{1 - p} \right) \div 1000$
Capacitor Power Q_C when operated in lower system voltage	[kVAR]	$kVAR_{System} = kVAR_{Capacitor} \times \left(\frac{V_{System}}{V_{Capacitor}} \right)^2$
Capacitor Power Q_C when operated in a 50Hz network	[kVAR]	$kVAR_{50Hz} = kVAR_{60Hz} \times \left(\frac{50 \text{ Hz}}{60 \text{ Hz}} \right)$
Capacitor Current I	[A]	$Amps = I = \frac{kVAR \times 1000}{V_{LL} \times \sqrt{3}}$
Voltage Boost with capacitors operated	[%]	$Voltage \text{ boost} = \frac{Q_C \times Z_{XFMR}}{S_{XFMR}}$
Capacitive Reactance X_C	[Ohms]	$X_C = \frac{1}{2\pi f \times C}$
Resonance Frequency f_r	[Hz]	$f_r = f \times \sqrt{\frac{S_{SC}}{Q_C}}$

KEY SYMBOLS

V_{LL} Voltage (Line-Line) [V]

I Current [A]

f Network Frequency [Hz]

f_r Resonance Frequency [Hz]

C Capacitor Capacitance [F]

Q_C Capacitor Power [kVAR]

p Detuning Factor [%]

Z_{XFMR} Transformer Short Circuit Power [%]

S_{XFMR} Transformer Power [kVA]

S_{SC} Short Circuit Power network [MVA]

LEADING-EDGE TECHNOLOGY FOR SAFE AND RELIABLE NETWORK SOLUTIONS

Since 1928



Capacitor Duty Contactors

- Patented design for capacitors
- Pre-insertion resistors
- Suppresses voltage transients during switching
- Dampens capacitor inrush current
- Rated life >100,000 operations
- Can extend capacitor life
- For 600V or less



Modular Capacitor Assemblies

- Pre-engineered auto-switching capacitor assemblies
- Capacitors, contactors, busbar system and fuses. Filter reactors are optional.
- One or two stages up to 100kVAR
- 240V, 480V and 600V
- Fast and easy assembly of large automatic PFC systems



PF Controllers (Relays)

- Auto-commissioning
- Harmonic data displayed
- 1-phase or 3-phase
- 6 or 12 stage
- AC or DC control

FRAKO North America Office:

Allied Industrial Marketing, Inc.
W67 N222 Evergreen Boulevard, Suite #209
Cedarburg, WI 53012

Phone: 1-262-618-2403 (GMT -6)
info@alliedindustrialmarketing.com
www.alliedindustrialmarketing.com