



# Capacitor Switching Contactors

Types K3-..A.. and K3-..K..

Ideal for Power Factor and Harmonic Filter Systems

## Features that matter

- Patented design with significant damping of inrush current
- Long life tested for up to 100,000 operations
- High reliability with low power losses
- Available for use in system with or without reactors

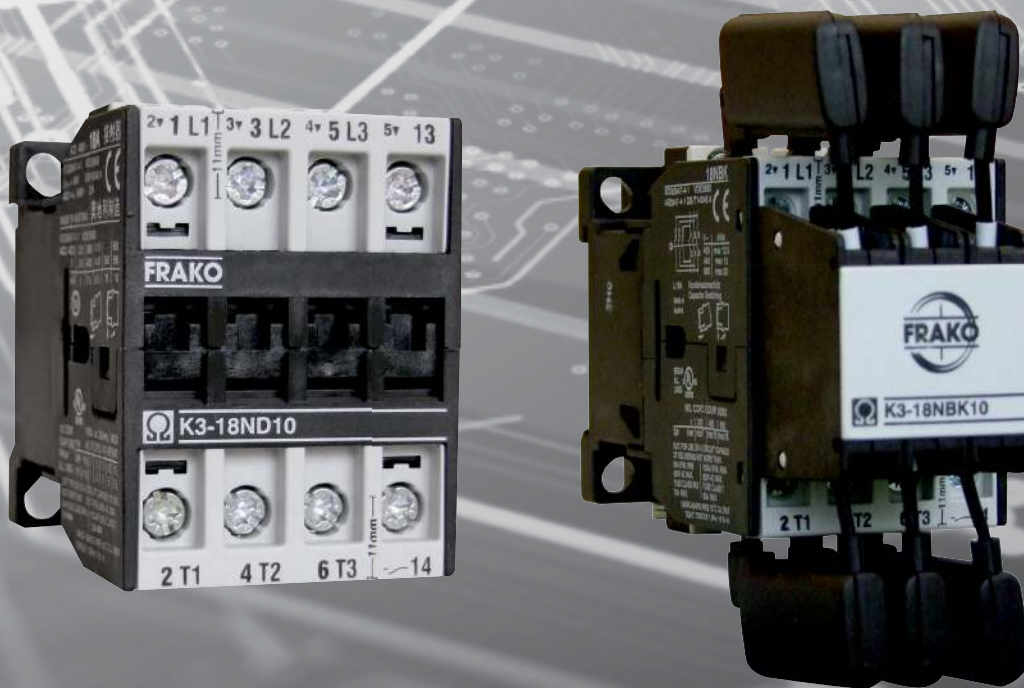

SOLUTIONS



## SPECIAL CONTACTOR FEATURES

Achieve reliability and long life expectancy for your capacitor and harmonic filter systems

During the switching of capacitors, that do not include series reactors (for tuning or detuning), peak switching currents of up to 200 times the nominal capacitor current can occur. This high peak current stresses both the capacitor as well as the contacts of the contactors. These switching currents can lead to reduced capacitor life and welding of the main contactor contacts.

## CONTACTORS WITH PRE-CHARGE RESISTORS (K3-..K.. TYPE)

Modern capacitor systems use special contactors that are equipped with resistors to suppress the switching currents. The resistors are switched in series with the capacitor prior to closing of the main contacts and removed from the circuit after energization.

This feature is referred to as leading transition contact with pre-charge or pre-insertion resistor and offers these advantages:

- Significant damping of inrush current
- Suppression of voltage transients during switching
- Protection for both capacitor and contactor
- Extended capacitor and contactor life
- >100,000 switching operations



## CONTACTORS WITHOUT PRE-CHARGE RESISTORS (K3-..A.. TYPE)

Capacitors with series reactors (for tuning or detuning) have lower peak inrush current than for systems that do not include reactors. For these applications, **FRAKO** offers contactors with special wear resistant contact material which enables them to switch the reactor/capacitor network without the need for pre-charge resistors.

These special contactors offer several advantages for capacitor switching applications that include series connected reactors:

- Safe switching (ON and OFF) of reactor/capacitor steps
- Improved voltage quality made possible through chatter-proof switching operations
- Extended capacitor life
- Extended contactor life (>100,000 switching operations)
- Increased system reliability



# MINIMIZE CAPACITOR SWITCHING TRANSIENTS

Achieve reliability and long life expectancy  
for your capacitor and harmonic filter systems

During normal switching of capacitors, a high inrush current flows from the power source into the capacitor. The amplitude of this current is a function of power source rated capacity and impedance, the switched capacitance and other capacitance already connected to the power system. The inrush current usually dissipates within one cycle, but may cause oscillations that last longer depending on the nature of the power system. Capacitor switching also produces an over-voltage transient, the magnitude of which depends upon the point on the sine wave where actual switching occurs. The magnitude of the peak voltage under this transient condition is generally between 1 - 2 per unit with respect to the system peak voltage. Switching transients can be reduced by using pre-charge resistors or series reactors.

## EXAMPLES OF CAPACITOR SWITCHING TRANSIENTS

Switched Load: 50kvar, 690V

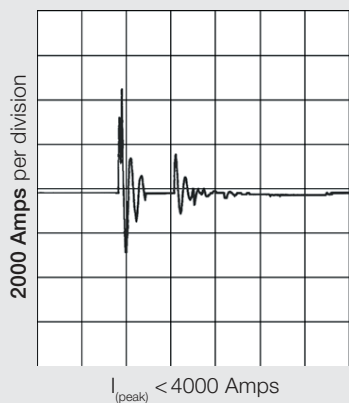

**Fig. 1: No Series Reactor & No Pre-Charge Resistors**

This oscillograph illustrates the inrush current measured for a 50kVAR capacitor on a 690V power system.

Note the vertical axis is 2000 Amps per division, so the magnitude of the inrush current in this case is over 4000 Amps (About 100 times nominal capacitor current).

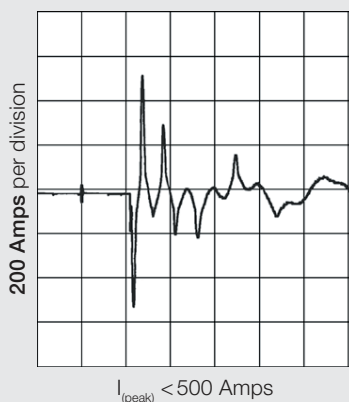

**Fig. 2: With Series Reactor & No Pre-Charge Resistors**

This oscillograph illustrates the inrush current measured for a 50kVAR capacitor on a 690V power system when a series reactor is included. Note the vertical axis is now only 200 Amps per division, so the magnitude of the inrush current in this case is about 500 Amps (About 12 times nominal capacitor current).

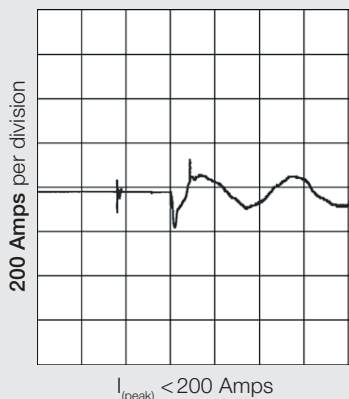

**Fig. 3: With Series Reactor & With Pre-Charge Resistor**

This oscillograph illustrates the benefit of using pre-charge resistors. Note the vertical axis is 200 Amps per division, so the magnitude of the inrush current in this case is less than 200 Amps (About 5 times nominal capacitor current).

# CONTACTORS WITH PRE-CHARGE RESISTORS

K3-..K.. for capacitors without series reactors



**FRAKO capacitor switching contactors are designed for long life, yet they are compact and have low power losses.**

When switched capacitors do not include series connected reactors, it is very important to use contactors with pre-charge resistors. Use K3-..K contactors with pre-charge resistors for switching capacitors that do not have a series reactor (filter, tuning, detuning, etc.). The pre-charge resistors will reduce transients associated with typical capacitor switching and extend capacitor life.

## SELECTING THE PROPER CONTACTOR K3-..K

**FRAKO** Type K contactors are rated for a specific range of capacitive current (or kVAR). This is due to the coordination of the resistor values for proper suppression of transients. Both the current and kVAR ratings apply to the total kVAR taking into account the boosting effect of series connected reactors. For example, a 7% detuning reactor will boost capacitor kVAR and current by 7.5%.

Part No.	Rating at 50° C	208 V	240 V	480 V	600 V	Aux. contacts		
	max. Amps	kVAR (range)				built-in		add
						NO	NC	Pcs.
K3-18NBK10 - 110	0 - 18	0 - 6	0 - 7	0 - 15	0 - 18	1	-	1 <sup>1)</sup>
K3 - 24K00 - 110	14 - 28	4.5 - 10	5.5 - 11	11.5 - 25	14.5 - 30	-	-	3 <sup>2)</sup>
K3 - 32K00 - 110	14 - 36	4.5 - 12.5	5.5 - 15	11.5 - 30	14.5 - 35	-	-	3 <sup>2)</sup>
K3 - 50K00 - 110	30 - 48	10 - 16.7	12.5 - 20	25 - 40	31 - 50	-	-	3 <sup>2)</sup>
K3 - 62K00 - 110	30 - 72	10 - 25	12.5 - 30	25 - 60	31 - 75	-	-	3 <sup>2)</sup>
K3 - 74K00 - 110	30 - 108	10 - 32	12.5 - 36	25 - 72	31 - 90	-	-	3 <sup>2)</sup>
K3 - 90K00 - 110	50 - 115	17 - 40	20 - 47	40 - 95	50 - 120	-	-	6 <sup>3)</sup>
K3 - 115K00 - 110	50 - 144	17 - 46	20 - 56	40 - 114	50 - 143	-	-	6 <sup>3)</sup>



Type K3-..K Contactor with pre-charge resistors

<sup>1)</sup> 1 × HN for top mounting      <sup>2)</sup> 1 × HN for top mounting + 2 × HB for side mounting

<sup>3)</sup> 2 × HB on the left or right side and 4 × HN for top mounting

### Auxiliary Contact Blocks

Article-No.	Type	Rated operational current			For contactors	Contacts		Weight approx. [kg/pc.]
		AC15 230 V [A]	400 V [A]	AC1 690 V [A]		NO	NC	
89-00294	HB11	3	2	10	K3-24... to K3-115...	1	1	0.02
89-00281	HN10	3	2	10	K3-18... to K3-115...	1	-	0.02

## COIL VOLTAGE

**FRAKO** contactors are supplied as standard with a coil voltage of 110-120Vac, 50/60Hz. As an option we can also provide contactors with 230-264 Vac, 50/60Hz coils (change suffix to -230). Other coil voltages are available upon request.





## CONTACTORS WITHOUT PRE-CHARGE RESISTORS

K3-..A.. for capacitors with series reactors

**FRAKO capacitor switching contactors are designed for long life, yet they are compact and have low power losses.**

Capacitors that include series connected reactors, do not require pre-charge resistors. Use K3-..A contactors for switching capacitors that have a series reactor (filter, tuning, detuning, etc.) that reduces transients normally associated with the switching of capacitors.

### SELECTING THE PROPER CONTACTOR K3-..A

**FRAKO** Type A contactors (without pre-charge resistors) are rated for the maximum capacitive current (or kVAR). Both the current and kVAR ratings apply to the total kVAR taking into account the boosting effect of series connected reactors. For example, a 7 % detuning reactor will boost capacitor kVAR and current by 7.5 %.

Part No.	Rating at 50° C	208 V	240 V	480 V	600 V	Aux. contacts		
	max. Amps	kVAR (range)				built-in		add
						NO	NC	Pcs.
K3-18ND10-110	18	6	7	15	18	1	-	4 <sup>1)</sup>
K3-24A00-110	28	10	11	25	30	-	-	6 <sup>2)</sup>
K3-32A00-110	36	12.5	15	30	35	-	-	6 <sup>2)</sup>
K3-50A00-110	48	16.7	20	40	50	-	-	6 <sup>2)</sup>
K3-62A00-110	72	25	30	60	75	-	-	6 <sup>2)</sup>
K3-74A00-110	108	32	36	72	90	-	-	6 <sup>2)</sup>
K3-90A00-110	115	40	47	95	120	-	-	9 <sup>3)</sup>
K3-115A00-110	144	46	56	114	143	-	-	9 <sup>3)</sup>



Type K3...A Contactor without pre-charge resistors

<sup>1)</sup> 1×HN for top mounting      <sup>2)</sup> 1×HN for top mounting + 2×HB for side mounting

<sup>3)</sup> 2×HB on the left or right side and 4×HN for top mounting

### Auxiliary Contact Blocks

Article-No.	Type	Rated operational current			For contactors	Contacts		Weight approx. [kg/pc.]
		AC15 230V [A]	400V [A]	AC1 690V [A]		NO	NC	
89-00294	HB11	3	2	10	K3-24... to K3-115...	1	1	0.02
89-00281	HN10	3	2	10	K3-18... to K3-115...	1	-	0.02

### COIL VOLTAGE

**FRAKO** contactors are supplied as standard with a coil voltage of 110-120Vac, 50/60Hz. As an option we can also provide contactors with 230-264 Vac, 50/60Hz coils (change suffix to -230). Other coil voltages are available upon request.



## TECHNICAL DATA

### Electrical Data



## MAXIMUM CURRENT (CONTINUOUS)

K3...K Contactors (with resistors)	K3-18NBK	K3-24K	K3-32K	K3-50K	K3-62K	K3-74K	K3-90K	K3-115K
Amps in 50° C ambient	0-18	14-28	14-36	30-48	30-72	30-108	50-115	50-144
Amps in 60° C ambient	0-18	14-28	14-36	30-48	30-72	30-87	50-108	50-130

K3...A Contactors (with resistors)	K3-18ND	K3-24A	K3-32A	K3-50A	K3-62A	K3-74A	K3-90A	K3-115A
Amps in 50° C ambient	18	28	36	48	32	108	115	144
Amps in 60° C ambient	18	28	36	48	72	87	108	130

## GENERAL SPECIFICATION

Parameter	K3-18	K3-24	K3-32	K3-50	K3-62	K3-74	K3-90	K3-115
Maximum Voltage	600V	600V	600V	600V	600V	600V	600V	600V
Switching Time (msec)	8-16	10-25	10-25	12-28	12-28	12-28	20-35	20-35
Typical RK5 Fuse (A)	50	90	125	200	250	300	300	300
Typical T Fuse (A)	70	110	150	175	175	175	300	300
Power Loss (Watts)	3.5W	4.7W	5.3W	9.2W	10.9W	12.5W	9.3W	11.0W
Terminal capacity Flexible (awg)	2x (18-10)	1x (14-4)	1x (14-4)		1x (10-0)		1x (18-3/0) plus 1x (8-4/0)	
Terminal capacity Solid (awg)	2x (18-10)	1x (16-10)	1x (16-10)	1x (12-10)	1x (12-10)	1x (12-10)	1x (18-3/0) plus 1x (8-4/0) only use flexible wires	
Coil Voltage range	85 % to 110 % of rated coil voltage							
Coil Terminals Flexible (awg)	18-12	18-12	18-12	18-12	18-12	18-12	18-12	18-12
Coil Terminals Solid (awg)	14-12	14-12	14-12	14-12	14-12	14-12	14-12	14-12
Weight (kg)	0.34	0.62	0.62	1.0	1.0	1.0	2.3	2.3
UL Approval	File # E 41502 for USA and Canada (UL - 508)							

# TECHNICAL DATA

Dimensional Drawings (mm)



K3 - 18NBK

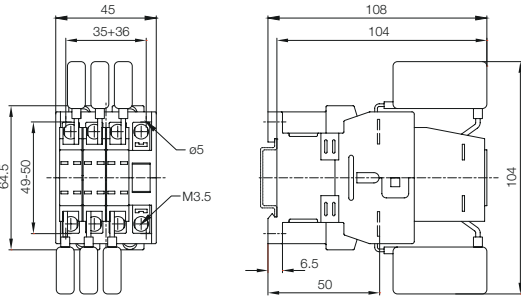

K3 - 18ND10

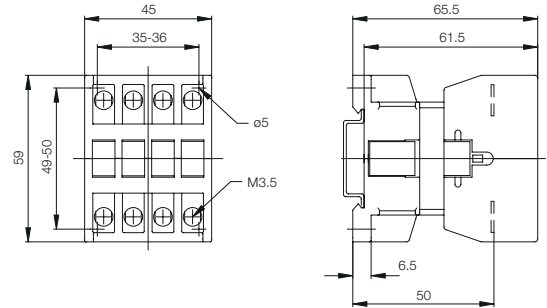

K3 - 24K00  
K3 - 32K00

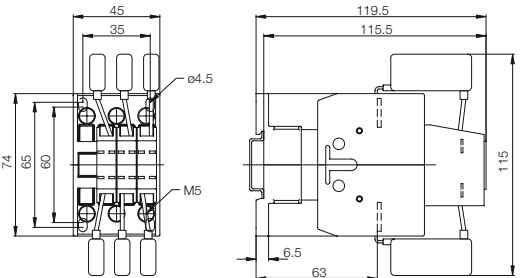

K3 - 24A00  
K3 - 32A00

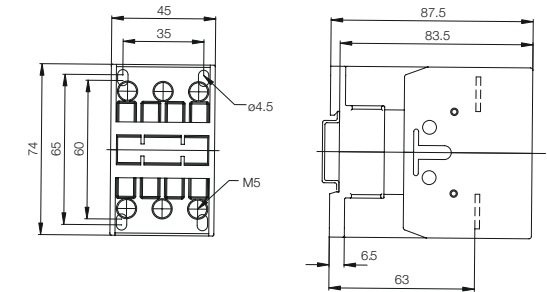

K3 - 50K00  
K3 - 62K00  
K3 - 74K00

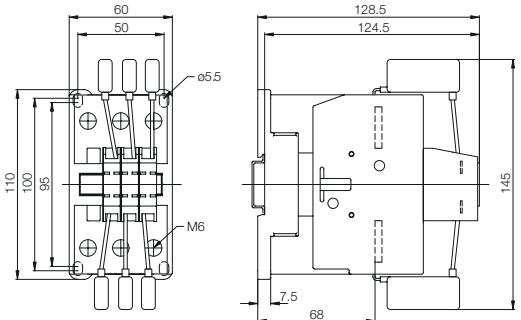

K3 - 50A00  
K3 - 62A00  
K3 - 74A00

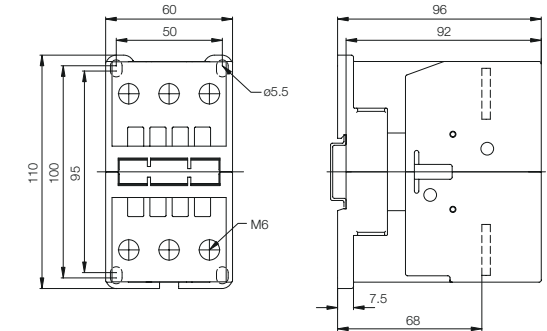

K3 - 90K00  
K3 - 115K00

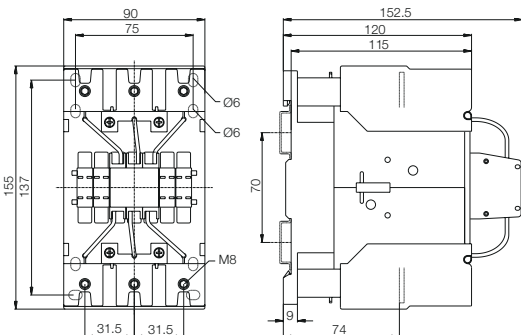

K3 - 90A00  
K3 - 115A00

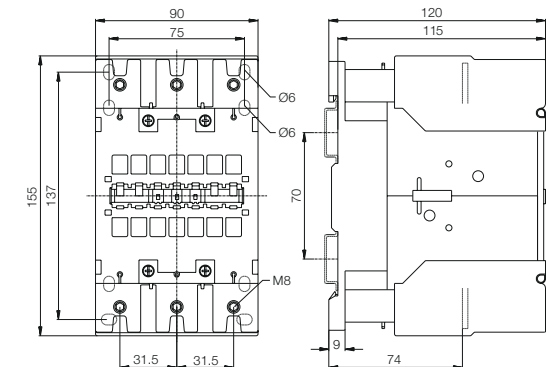

# CAPACITOR INNOVATION, DEVELOPMENT AND PRODUCTION since 1928



## AC POWER CAPACITORS

- Dry type design
- 240V to 800V, up to 30kVAR
- Four-fold safety features
- For harmonic filters and power factor systems
- High current capability up to 165% of nominal capacitor current
- Ambient temperature up to 68° C
- Altitude up to 4000 meters
- Patented terminal for fast wiring, maintenance free operation



## PF CONTROLLERS (RELAYS)

- Auto-commissioning
- Harmonic data displayed
- 1-phase or 3-phase
- 6 or 12 stage
- AC or DC control

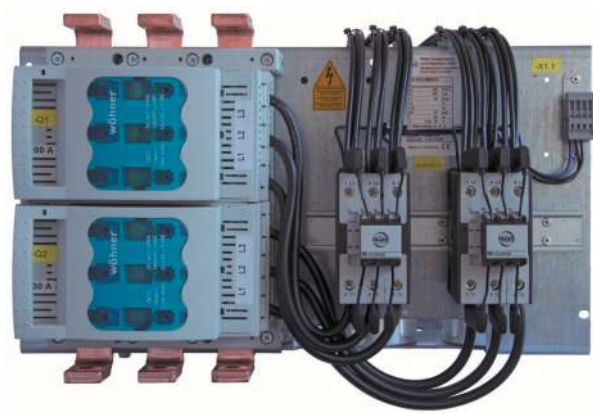

## MODULAR CAPACITOR ASSEMBLIES

- Capacitors, contactors, busbar system and fuses. Filter reactors are optional.
- One or two stages up to 100kVAR
- 240V , 480V and 600V
- Fast and easy assembly of large automatic PFC systems

FRAKO North America Office:

Allied Industrial Marketing, Inc.  
W67N222 Evergreen Boulevard, Suite #209  
Cedarburg, WI 53012

Phone: 1-262-618-2403 (GMT -6)  
info@alliedindustrialmarketing.com  
www.alliedindustrialmarketing.com